

FW4 915x445 Cover and Frame Only (BRSK)

Product Image

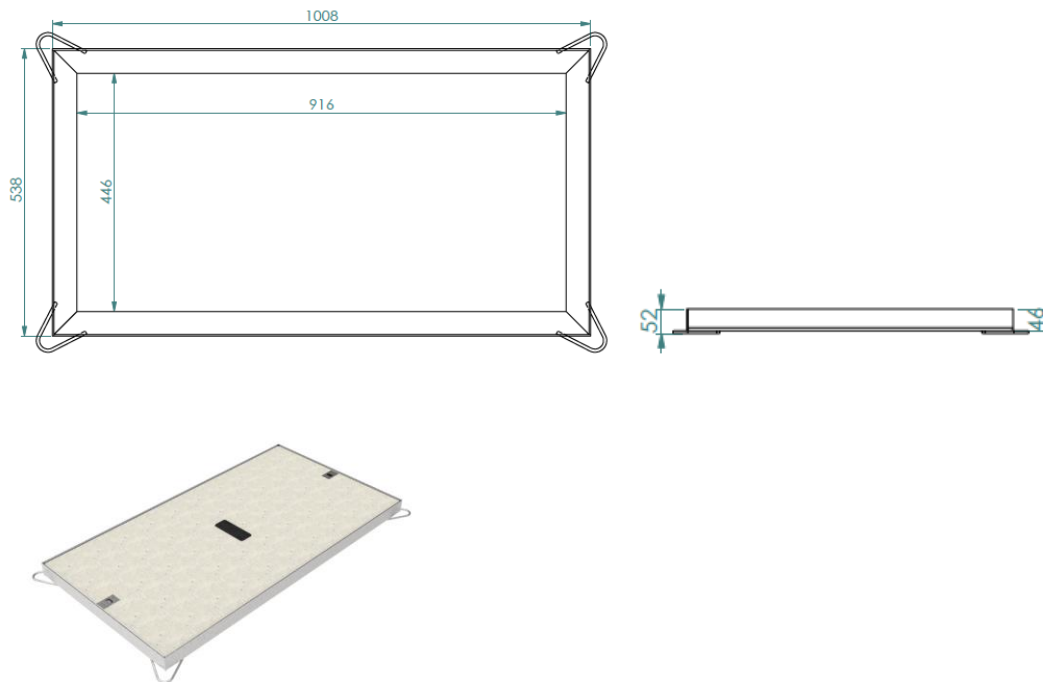

Product Description

Concrete Infill covers are manufactured to suit an extensive range of clear openings, an industry favourite for their simplicity and ease of use.

The product is designed for use in both footway and roadway installations where it provides access to underground ducting (EN124 Class A15-B125).

Frame Details

Clear Opening: 916mm x 446mm

External Dimensions: 1008mm x 538mm

Depth: 52mm

Weight: 6.5kg

Cover Details

Cover Type: 1 x 1000mm x 530mm

Weight: 64kg

Key Features

- Easy slide out covers
- No inherent scrap value
- Anti-slip surface